

**TYPICAL 11 HOLES
EQUIDISTANT
1.270 [0.5] \pm 0.003 [0.001]
DIAMETER**

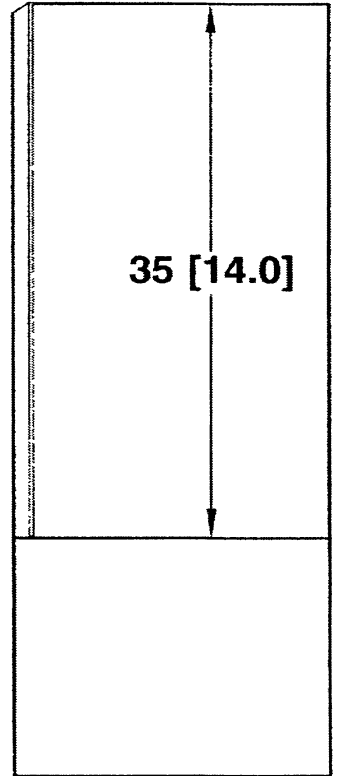
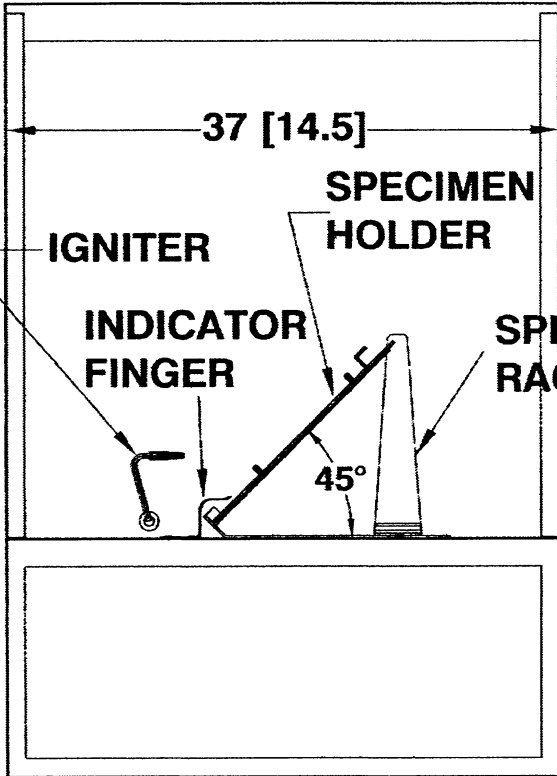

**NOTE: DIMENSIONS IN
CENTIMETERS [INCHES]
TOLERANCE \pm 1 CM [0.375]
UNLESS OTHERWISE NOTED**

**FLAMMABILITY APPARATUS VIEWS
FIGURE 2**